



HIGH INDUCTION LONG THROW DIFFUSERS FOR DEEP JET

KVA
SERIES

GENERAL OVERVIEW

OVERVIEW:

Adjustable direction air diffusers with patented system for rapid assembly on round or rectangular air ducts.

The airflow can be directed with an angle of approx. 45° with respect to the axis and a rotation of 360°.

The airflow can be regulated by a special damper inside the diffuser, directed outwards.

MATERIAL AND FINISH:

Nozzle in ABS RAL 7005.

Coupling in EPDM RAL 7005.

INSTALLATION:

Insert the connector in the opening (Ø113mm for KVA 50 and Ø168mm for KVA 100) already made in the duct and secondly insert the diffuser in the nozzle.

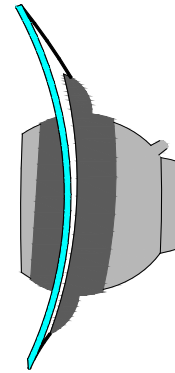

INSTALLATION ON CIRCULAR DUCT

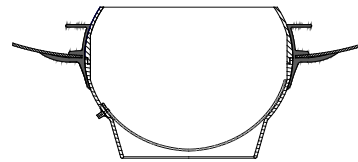

INSTALLATION ON POLYURETHAINE DUCT

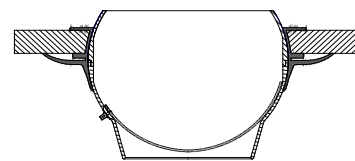

KVA 50

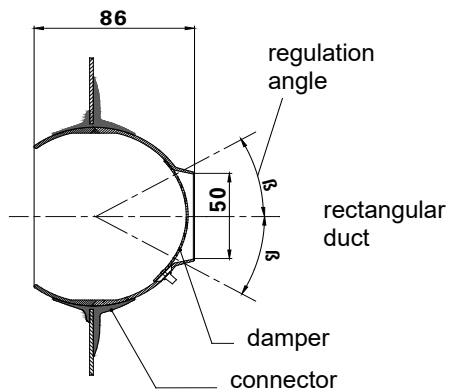

KVA 100

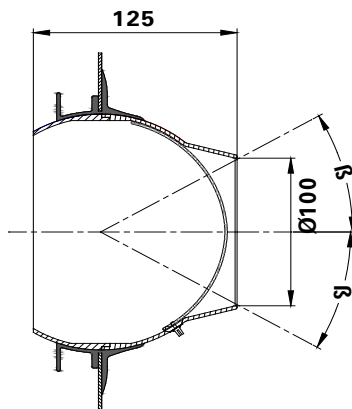

HOW TO ORDER

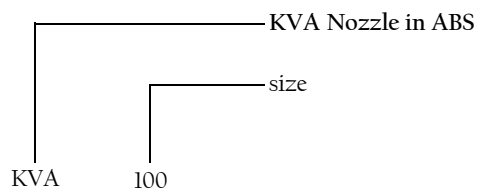



HIGH INDUCTION LONG THROW DIFFUSERS FOR DEEP JET

KVA
SERIES

PERFORMANCE

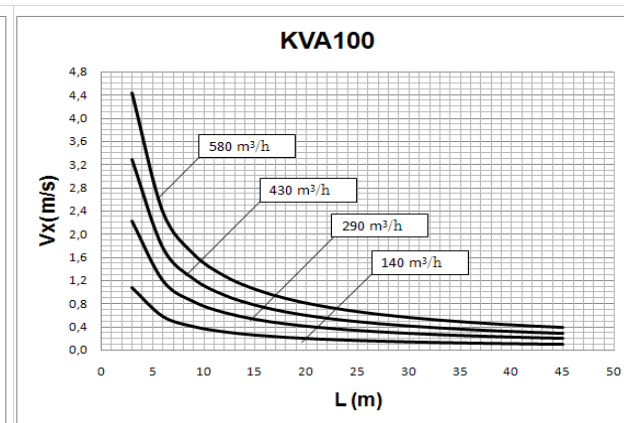
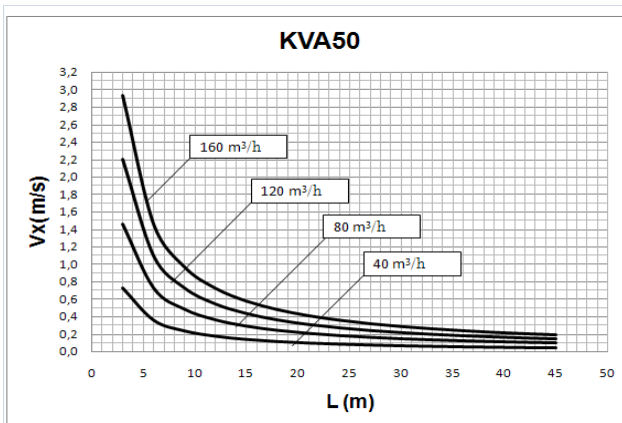
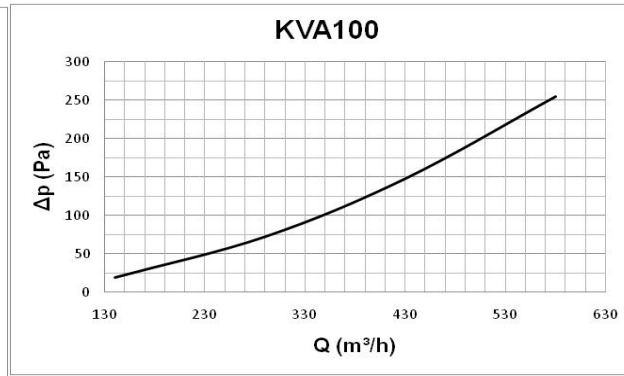
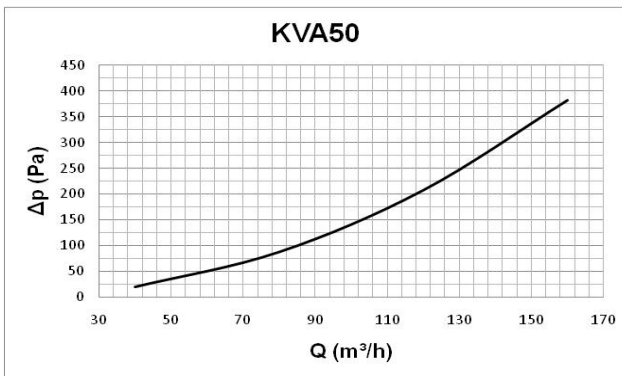
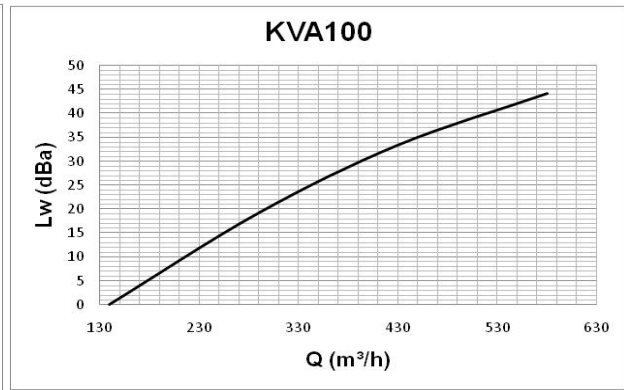
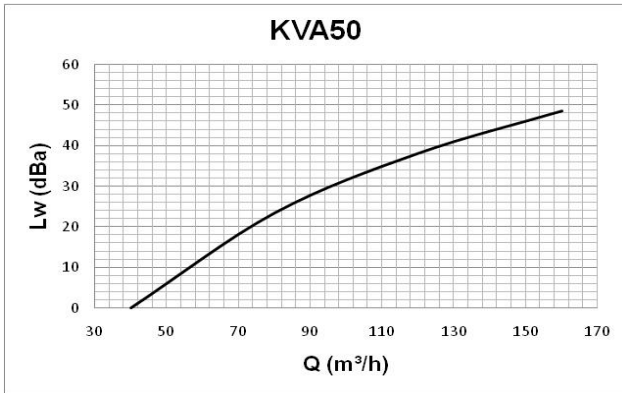

Data measured in reverberation chamber in accordance with international standards:

ISO 3741 1999: Acoustic - determination of sound power levels of noise sources using sound pressure - Precision methods for reverberation rooms
 ISO 5135 1997: Acoustic - determination of sound power levels of noise from air-terminal devices; air terminal units; dampers and valves by measurement in a reverberation room.

The shown data does not take into consideration the attenuation resulting from the surroundings where the diffuser is installed. Such attenuation is normally included between 6 and 10 dBa and is determined by the size of the surrounding space, its shape and the characteristics of the furniture and room fittings.

Data obtained from mathematical modelling in CFD test chamber operating in virtual agreement with the International Standard:

ISO 5219 1984: Air distribution and air diffusion - Laboratory. Aerodynamic testing and rating of air terminal devices.