



SUPPLY AND EXTRACTION MULTIDIRECTIONAL DIFFUSER

KNF
SERIES

OVERVIEW TECHNICAL CHARACTERISTICS

OVERVIEW

The four-way KNF diffusers allow to obtain in a single diffuser both the supply of air from the side slots and the extraction of air from the central meshed panel.

The throw of the side supply in the four directions creates an inductive effect of recall towards the centre of the diffuser of air already present in the room which is immediately captured by the extraction.

FIXING

Fixing is made through the installation in a modular ceiling structure or through the hidden screws laterally to the neck of the diffuser. The central part of the diffuser is removable for ease of installation and connection.

MATERIALS AND FINISH

The KNF diffuser series is made of aluminium with central panel made of carbon steel perforated sheet painted white RAL 9010

UNSUITABLE ENVIRONMENTS

The aluminum products are not suitable for installation in environments with an atmosphere containing corrosive substances for this material and in particular containing chlorine, such as swimming pools, spas and some types of food industries.

The products in painted carbon steel are not suitable for installation in environments with high humidity and in environments with a potentially explosive atmosphere or containing powders or vapors of corrosive substances.



DIFFUSER	B [mm]	C [mm]	D* [mm]
600 x 600 1 slot	595	448	583
600 x 600 2 slots	595	448	583
600 x 600 3 slots	595	448	583
675 x 675 1 slot	670	523	658
675 x 675 2 slots	670	523	658
675 x 675 3 slots	670	523	658

*FINE LINE ONLY

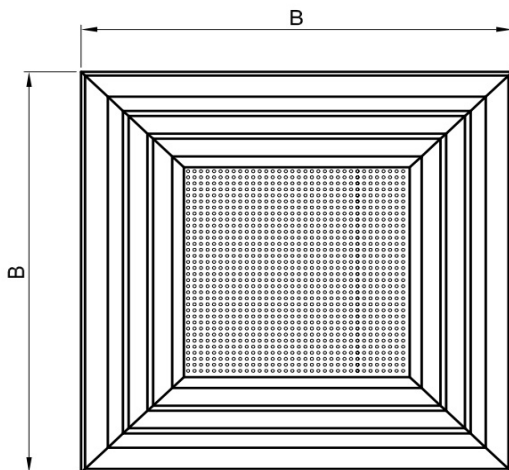
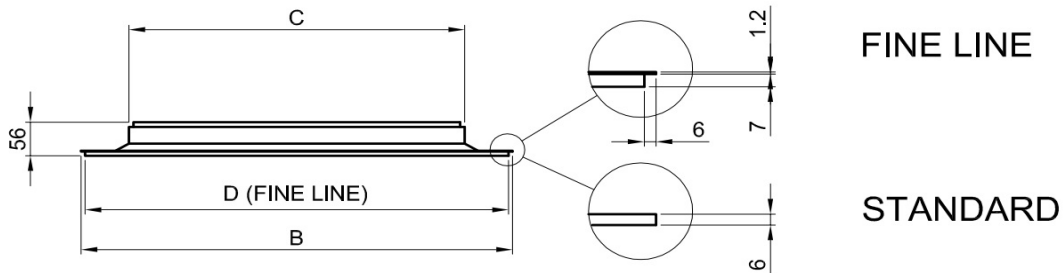

FILTER ON REQUEST

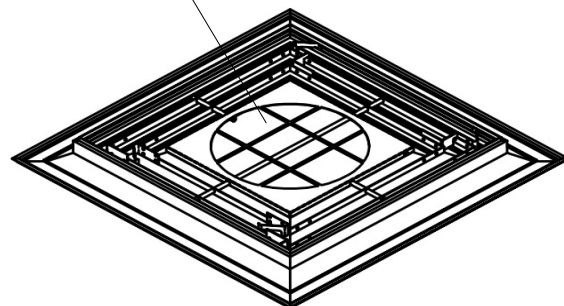



SUPPLY AND EXTRACTION MULTIDIRECTIONAL DIFFUSER

KNF
SERIES

KNF 600x600 ONE SLOT TECHNICAL DATA

KNF 1 600x600 - sound power

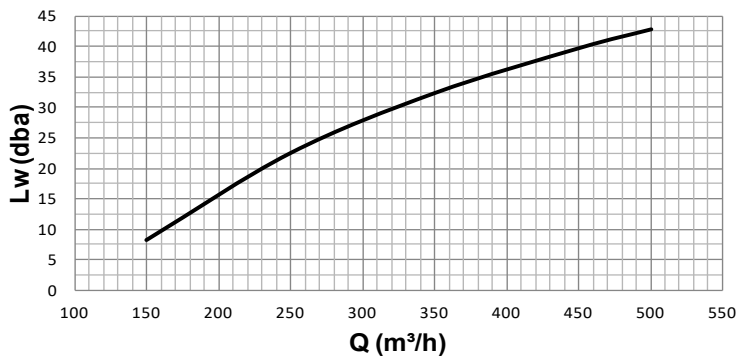

Acoustic data measured in reverberation room in accordance with international standards with the same air flow for supply and return:

ISO 3741 1999: *Acoustic - determination of sound power levels of noise sources using sound pressure - Precision methods for reverberation rooms*

ISO 5135 1997: *Acoustic - determination of sound power levels of noise from air-terminal devices; air terminal units; dampers and valves by measurement in a reverberation room.*

The shown data does not take into consideration the attenuation resulting from the surroundings where the diffuser is installed. Such attenuation is normally included between 6 and 10 dBa and is determined by the size of the surrounding space, its shape and the characteristics of the furniture and room fittings.

KNF 1 600x600 - pressure drop - supply

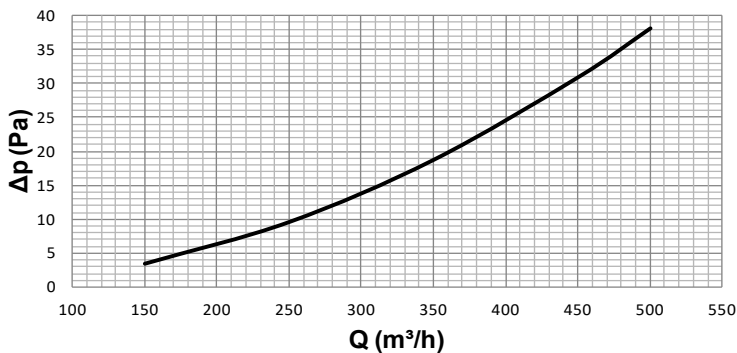

Pressure losses measured working in isothermal conditions in accordance with international standard:

ISO 5219 1984: *Air distribution and air diffusion - Laboratory. Aerodynamic testing and rating of air terminal devices.*

KNF 1 600x600 - pressure drop - return

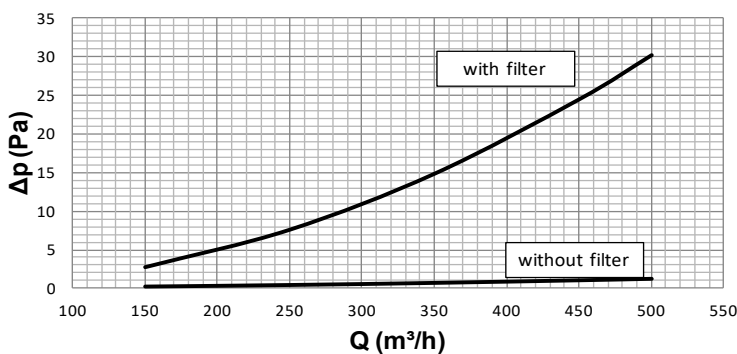



SUPPLY AND EXTRACTION MULTIDIRECTIONAL DIFFUSER

KNF
SERIES

KNF 600x600 ONE SLOT
TECHNICAL DATA

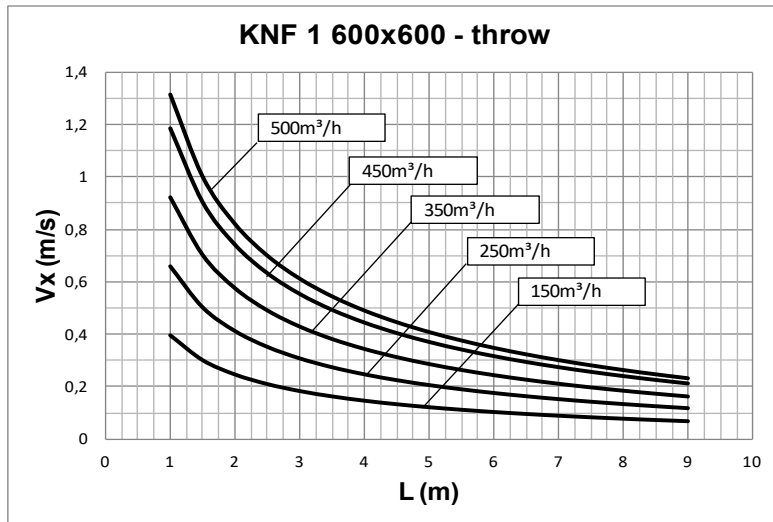

Data measured working in isothermal conditions in accordance with international standard: ISO 5219 1984: *Air distribution and air diffusion - Laboratory. Aerodynamic testing and rating of air terminal devices.*

L (m) horizontal distance in metres from the centre of the diffuser
Vx (m/s) maximum speed inside the air stream



SUPPLY AND EXTRACTION MULTIDIRECTIONAL DIFFUSER

KNF
SERIES

KNF 600x600 TWO SLOTS TECHNICAL DATA

KNF 2 600x600 - sound power

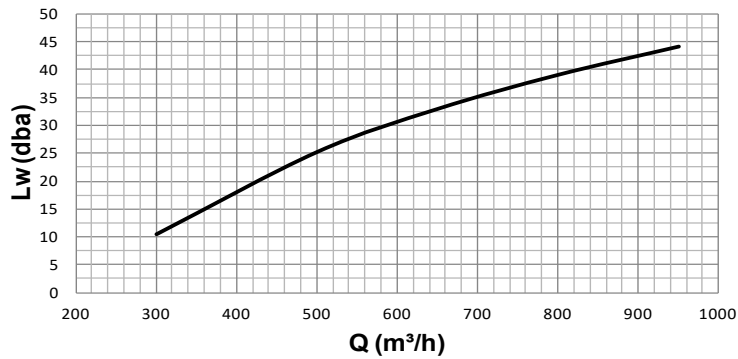

Acoustic data measured in reverberation room in accordance with international standards with the same air flow for supply and return:

ISO 3741 1999: *Acoustic - determination of sound power levels of noise sources using sound pressure - Precision methods for reverberation rooms*

ISO 5135 1997: *Acoustic - determination of sound power levels of noise from air-terminal devices; air terminal units; dampers and valves by measurement in a reverberation room.*

The shown data does not take into consideration the attenuation resulting from the surroundings where the diffuser is installed. Such attenuation is normally included between 6 and 10 dBa and is determined by the size of the surrounding space, its shape and the characteristics of the furniture and room fittings.

KNF 2 600x600 - pressure drop - supply

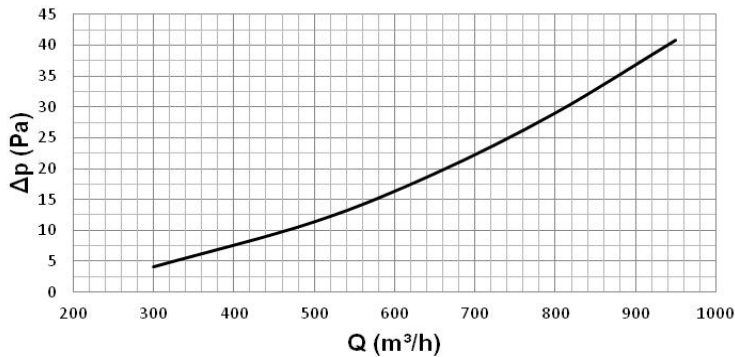

Pressure losses measured working in isothermal conditions in accordance with international standard:

ISO 5219 1984: *Air distribution and air diffusion - Laboratory. Aerodynamic testing and rating of air terminal devices.*

KNF 2 600x600 - pressure drop - return

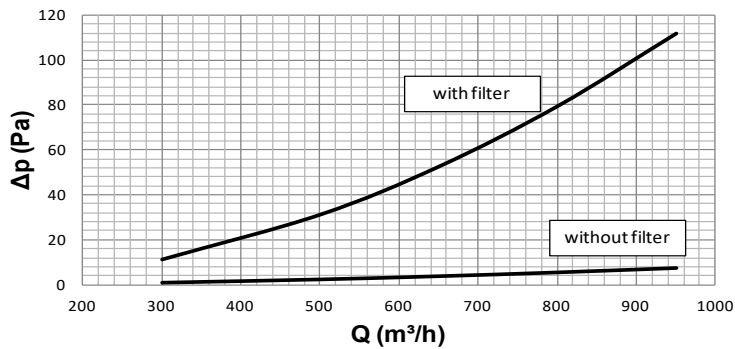



SUPPLY AND EXTRACTION MULTIDIRECTIONAL DIFFUSER

KNF
SERIES

KNF 600x600 TWO SLOTS
TECHNICAL DATA

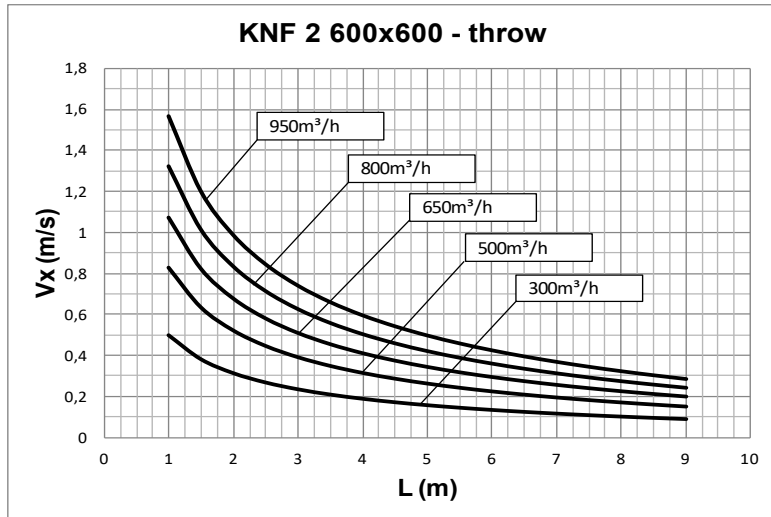

Data measured working in isothermal conditions in accordance with international standard:
ISO 5219 1984: *Air distribution and air diffusion - Laboratory. Aerodynamic testing and rating of air terminal devices.*

L (m) horizontal distance in metres from the centre of the diffuser
Vx (m/s) maximum speed inside the air stream



SUPPLY AND EXTRACTION MULTIDIRECTIONAL DIFFUSER

KNF
SERIES

KNF 600x600 THREE SLOTS TECHNICAL DATA

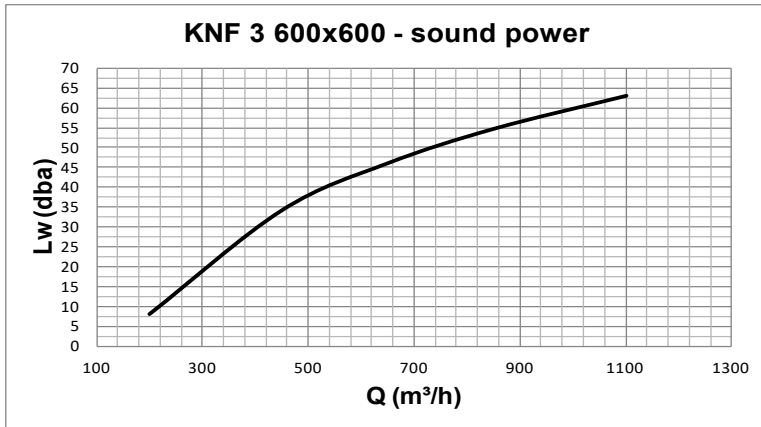

Acoustic data measured in reverberation room in accordance with international standards with the same air flow for supply and return:

ISO 3741 1999: *Acoustic - determination of sound power levels of noise sources using sound pressure - Precision methods for reverberation rooms*

ISO 5135 1997: *Acoustic - determination of sound power levels of noise from air-terminal devices; air terminal units; dampers and valves by measurement in a reverberation room.*

The shown data does not take into consideration the attenuation resulting from the surroundings where the diffuser is installed. Such attenuation is normally included between 6 and 10 dBa and is determined by the size of the surrounding space, its shape and the characteristics of the furniture and room fittings.

Pressure losses measured working in isothermal conditions in accordance with international standard:

ISO 5219 1984: *Air distribution and air diffusion - Laboratory. Aerodynamic testing and rating of air terminal devices.*

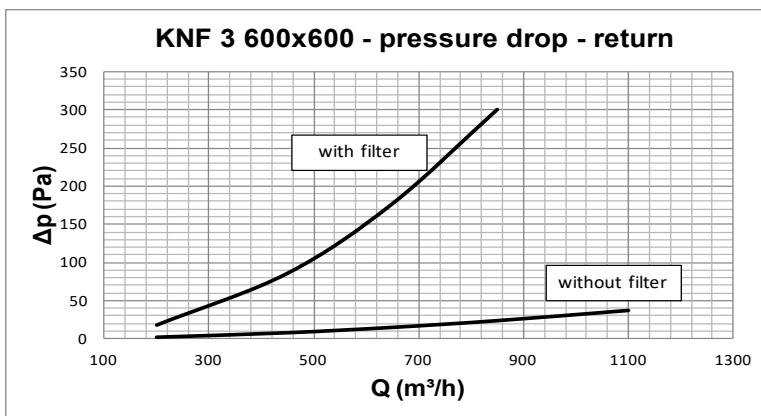
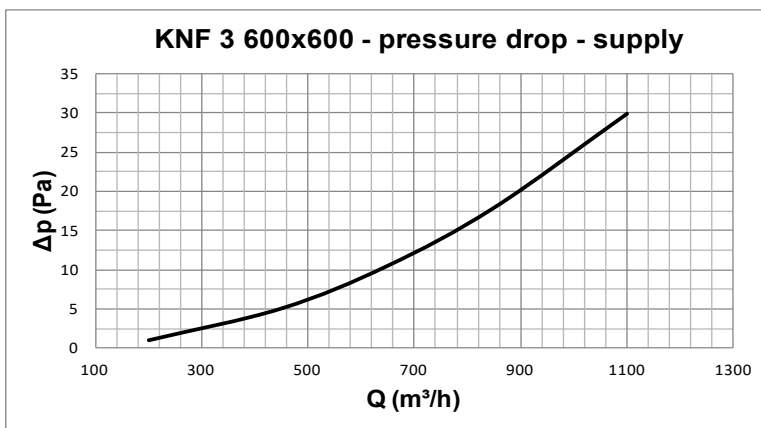



SUPPLY AND EXTRACTION MULTIDIRECTIONAL DIFFUSER

KNF
SERIES

KNF 600x600 THREE SLOTS
TECHNICAL DATA

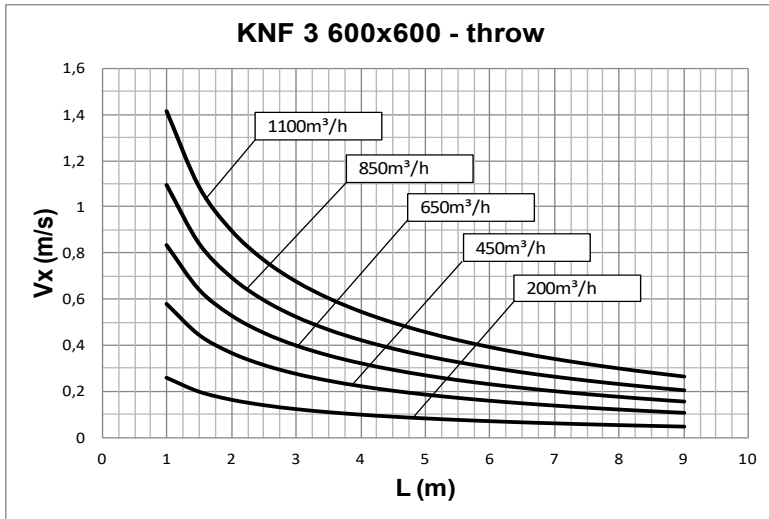

Data measured working in isothermal conditions in accordance with international standard:
ISO 5219 1984: *Air distribution and air diffusion - Laboratory. Aerodynamic testing and rating of air terminal devices.*

L (m) horizontal distance in metres from the centre of the diffuser
Vx (m/s) maximum speed inside the air stream



SUPPLY AND EXTRACTION MULTIDIRECTIONAL DIFFUSER

KNF
SERIES

KNF 675x675 ONE SLOT
TECHNICAL DATA

KNF 1 675x675 - sound power

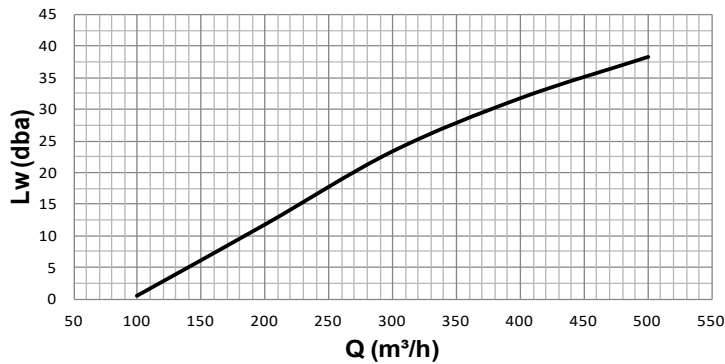

Acoustic data measured in reverberation room in accordance with international standards with the same air flow for supply and return:

ISO 3741 1999: *Acoustic - determination of sound power levels of noise sources using sound pressure - Precision methods for reverberation rooms*

ISO 5135 1997: *Acoustic - determination of sound power levels of noise from air-terminal devices; air terminal units; dampers and valves by measurement in a reverberation room.*

The shown data does not take into consideration the attenuation resulting from the surroundings where the diffuser is installed. Such attenuation is normally included between 6 and 10 dBa and is determined by the size of the surrounding space, its shape and the characteristics of the furniture and room fittings.

Pressure losses measured working in isothermal conditions in accordance with international standard:

ISO 5219 1984: *Air distribution and air diffusion - Laboratory. Aerodynamic testing and rating of air terminal devices.*

KNF 1 675x675 - pressure drop - supply

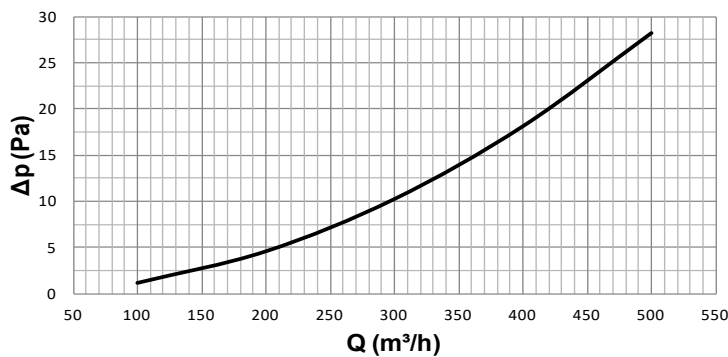

KNF 1 675x675 - pressure drop - return

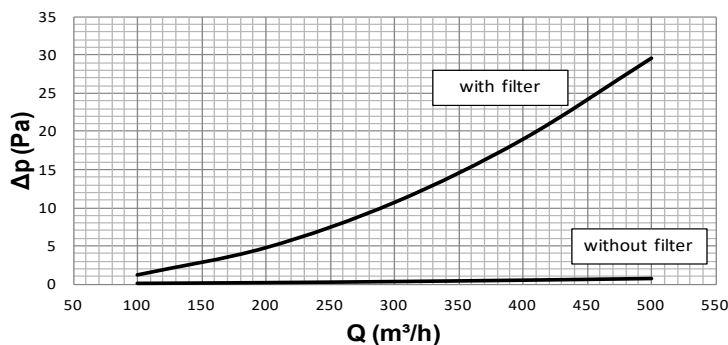



SUPPLY AND EXTRACTION MULTIDIRECTIONAL DIFFUSER

KNF
SERIES

KNF 675x675 ONE SLOT
TECHNICAL DATA

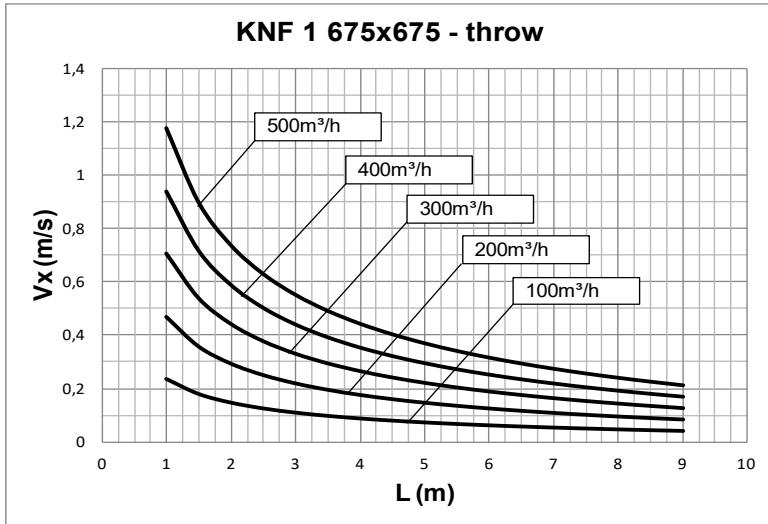

Data measured working in isothermal conditions in accordance with international standard: ISO 5219 1984: *Air distribution and air diffusion - Laboratory. Aerodynamic testing and rating of air terminal devices.*

L (m) horizontal distance in metres from the centre of the diffuser
Vx (m/s) maximum speed inside the air stream



SUPPLY AND EXTRACTION MULTIDIRECTIONAL DIFFUSER

KNF
SERIES

KNF 675x675 TWO SLOTS TECHNICAL DATA

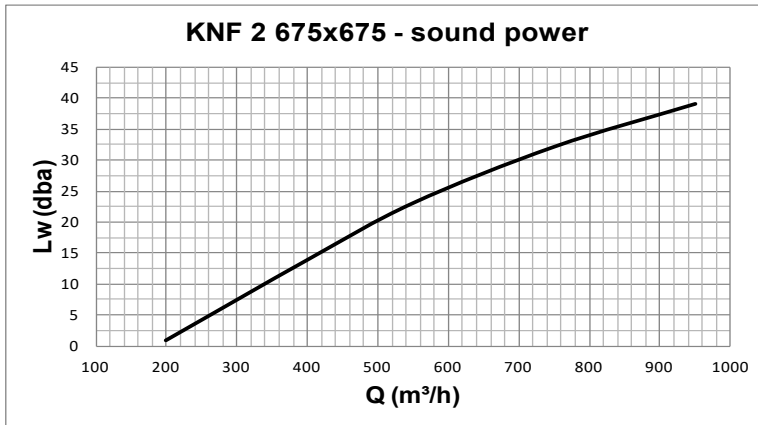

Acoustic data measured in reverberation room in accordance with international standards with the same air flow for supply and return:

ISO 3741 1999: *Acoustic - determination of sound power levels of noise sources using sound pressure - Precision methods for reverberation rooms*

ISO 5135 1997: *Acoustic - determination of sound power levels of noise from air-terminal devices; air terminal units; dampers and valves by measurement in a reverberation room.*

The shown data does not take into consideration the attenuation resulting from the surroundings where the diffuser is installed. Such attenuation is normally included between 6 and 10 dBa and is determined by the size of the surrounding space, its shape and the characteristics of the furniture and room fittings.

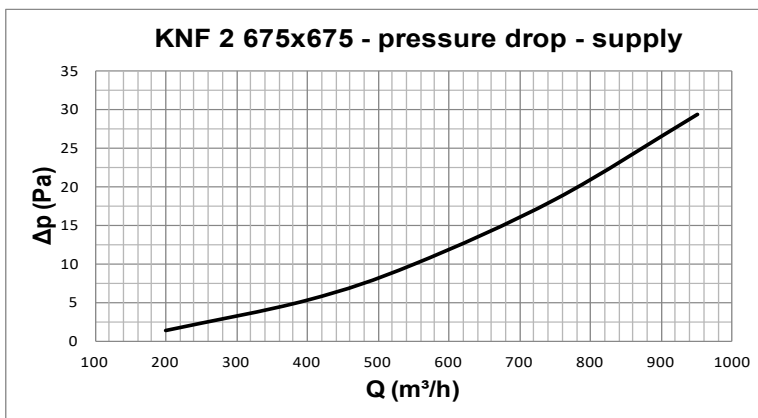

Pressure losses measured working in isothermal conditions in accordance with international standard:

ISO 5219 1984: *Air distribution and air diffusion - Laboratory. Aerodynamic testing and rating of air terminal devices.*

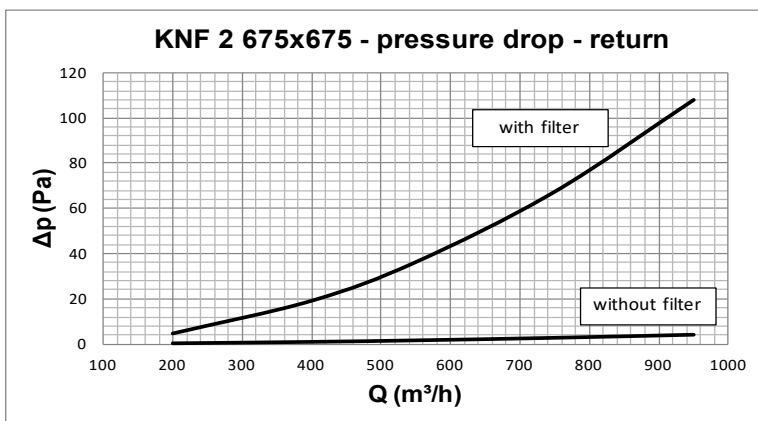



SUPPLY AND EXTRACTION MULTIDIRECTIONAL DIFFUSER

KNF
SERIES

KNF 675x675 TWO SLOTS
TECHNICAL DATA

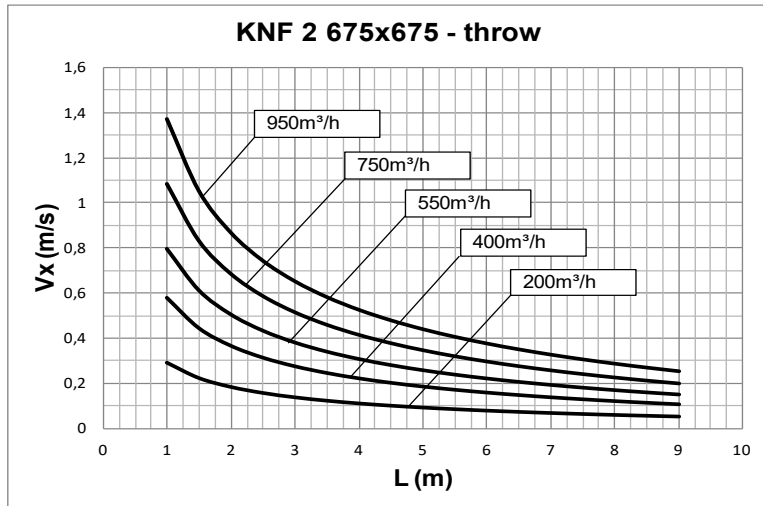

Data measured working in isothermal conditions in accordance with international standard:
ISO 5219 1984: *Air distribution and air diffusion - Laboratory. Aerodynamic testing and rating of air terminal devices.*

L (m) horizontal distance in metres from the centre of the diffuser
Vx (m/s) maximum speed inside the air stream



SUPPLY AND EXTRACTION MULTIDIRECTIONAL DIFFUSER

KNF
SERIES

KNF 675x675 THREE SLOTS TECHNICAL DATA

KNF 3 675x675 - sound power

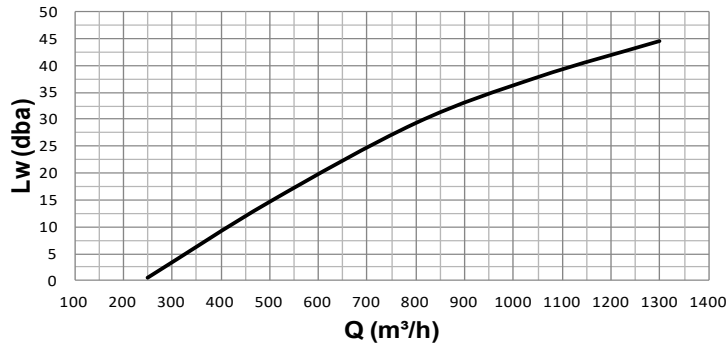

Acoustic data measured in reverberation room in accordance with international standards with the same air flow for supply and return:

ISO 3741 1999: *Acoustic - determination of sound power levels of noise sources using sound pressure - Precision methods for reverberation rooms*

ISO 5135 1997: *Acoustic - determination of sound power levels of noise from air-terminal devices; air terminal units; dampers and valves by measurement in a reverberation room.*

The shown data does not take into consideration the attenuation resulting from the surroundings where the diffuser is installed. Such attenuation is normally included between 6 and 10 dBa and is determined by the size of the surrounding space, its shape and the characteristics of the furniture and room fittings.

Pressure losses measured working in isothermal conditions in accordance with international standard:

ISO 5219 1984: *Air distribution and air diffusion - Laboratory. Aerodynamic testing and rating of air terminal devices.*

KNF 3 675x675 - pressure drop - supply

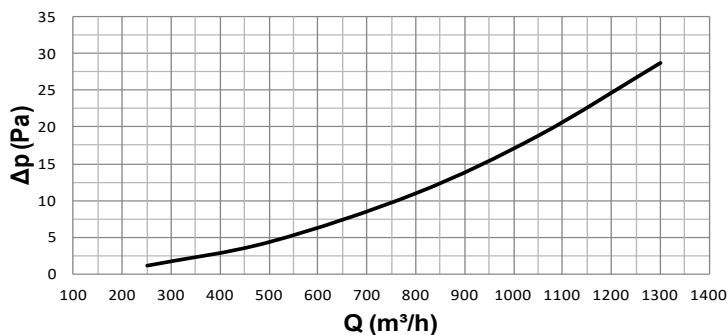

KNF 3 675x675 - pressure drop - return

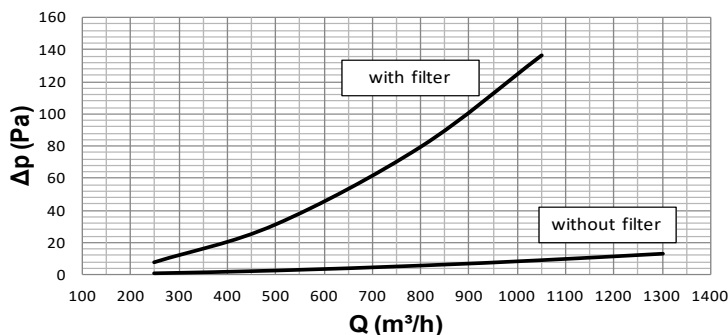



SUPPLY AND EXTRACTION MULTIDIRECTIONAL DIFFUSER

KNF
SERIES

KNF 675x675 THREE SLOTS
TECHNICAL DATA

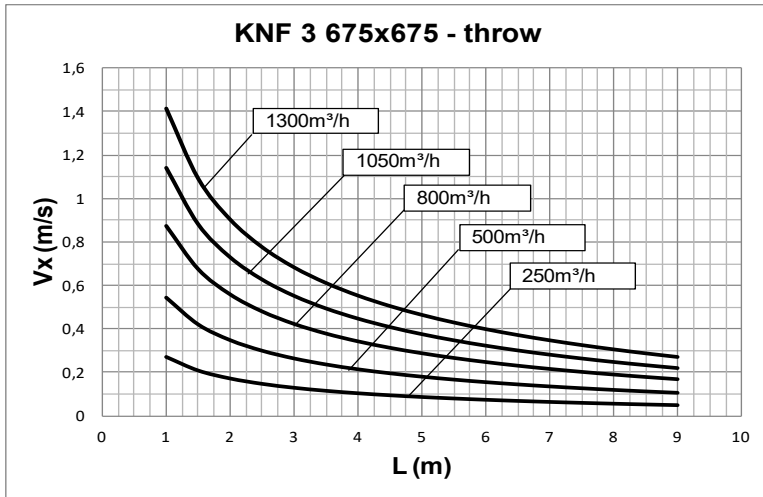

Data measured working in isothermal conditions in accordance with international standard: ISO 5219 1984: Air distribution and air diffusion - Laboratory. Aerodynamic testing and rating of air terminal devices.

L (m) horizontal distance in metres from the centre of the diffuser
Vx (m/s) maximum speed inside the air stream

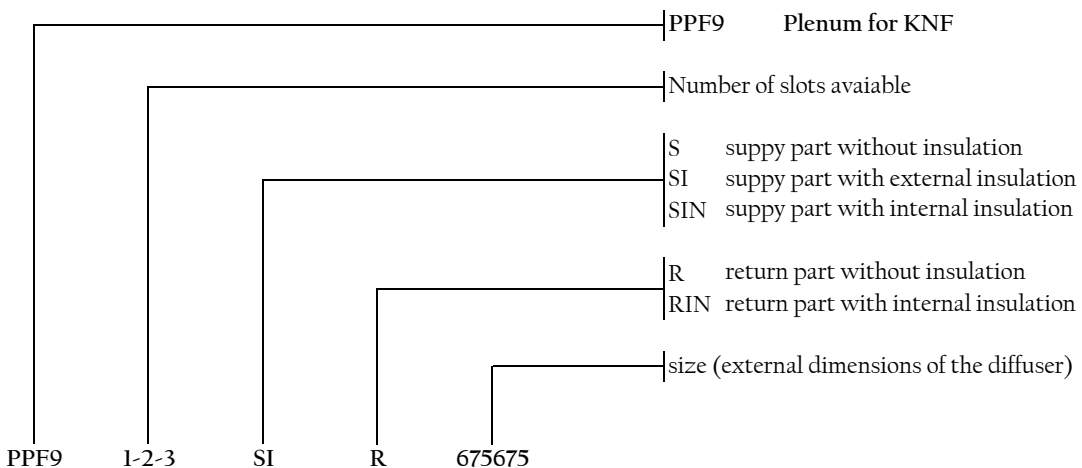
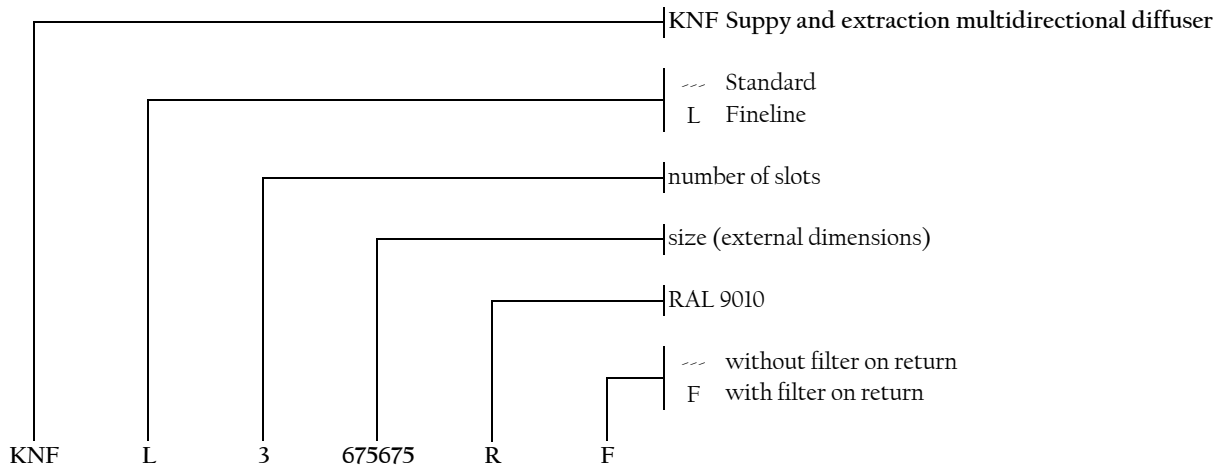



SUPPLY AND EXTRACTION MULTIDIRECTIONAL DIFFUSER

KNF
SERIES

PLENUM

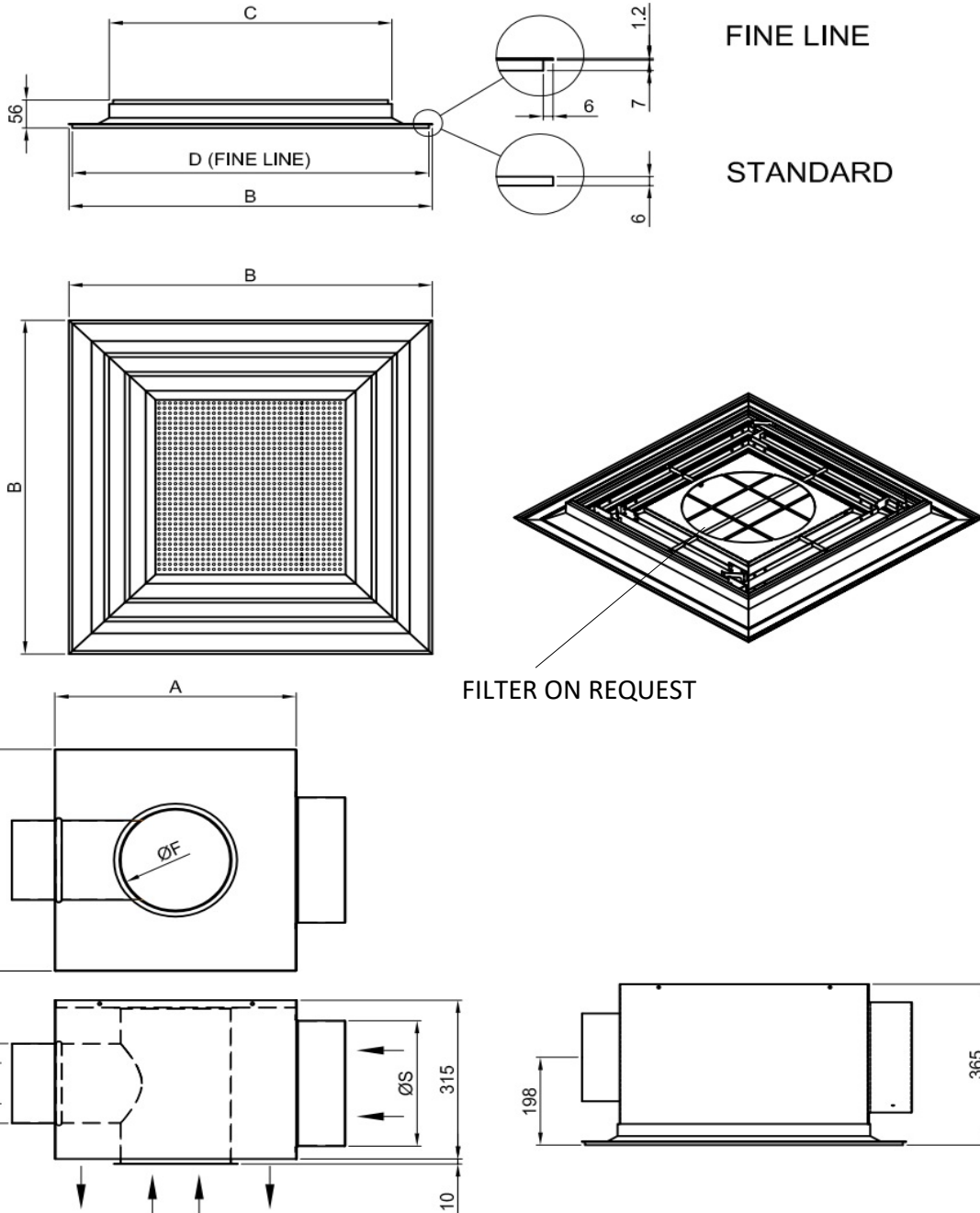

DIFFUSER	PLENUM	A [mm]	B [mm]	C [mm]	D* [mm]	ØE [mm] steel	ØS [mm] ABS	ØF [mm]
600 x 600 1 SLOT	PPF91-2...600600	438	595	448	583	198	249	270
600 X 600 2 SLOTS	PPF91-2...600600	438	595	448	583	198	249	270
600 X 600 3 SLOTS	PPF93...600600	438	595	448	583	158	249	200
675 X 675 1 SLOT	PPF91-2-3...675675	513	670	523	658	198	249	270
675 X 675 2 SLOTS	PPF91-2-3...675675	513	670	523	658	198	249	270
675 X 675 3 SLOTS	PPF91-2-3...675675	513	670	523	658	198	249	270

* FINE LINE ONLY