

HIGH-INDUCTION DIFFUSERS FOR COUNTERCEILING

KGQ
SERIES

KGQ - KGQT

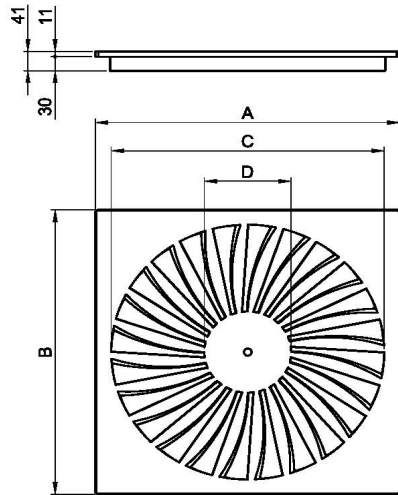

KGQR

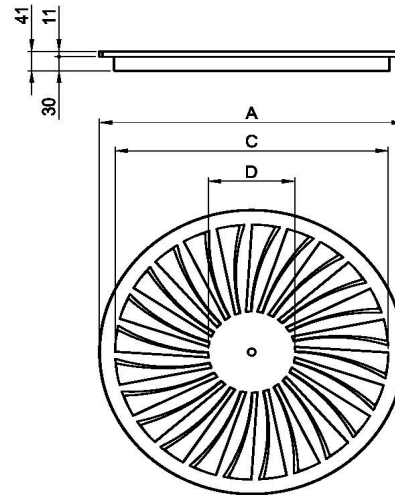

Model	Nominal size	A [mm]	B [mm]	Ø [mm]	C [mm]	D [mm]	N° of fins	Ak [m ²]
KGQ300	300	296	296	--	238	86	16	0,020
KGQ400	400	396	396	--	338	140	22	0,030
KGQ500	500	496	496	--	438	170	24	0,050
KGQ600	600	596	596	--	538	170	24	0,070
KGQ625	625	621	621	--	538	170	24	0,070
KGQT300	300	596	596	--	238	86	16	0,020
KGQT400	400	596	596	--	338	140	22	0,030
KGQT500	500	596	596	--	438	170	24	0,050
KGQR300	300	--	--	296	238	86	16	0,020
KGQR400	400	--	--	396	338	140	22	0,030
KGQR500	500	--	--	496	438	170	24	0,050
KGQR600	600	--	--	596	538	170	24	0,070
KGQR625	625	--	--	621	538	170	24	0,070

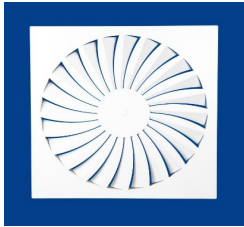

HIGH-INDUCTION DIFFUSERS FOR COUNTERCEILING

PERFORMANCE KGQ-300

KGQ
SERIES

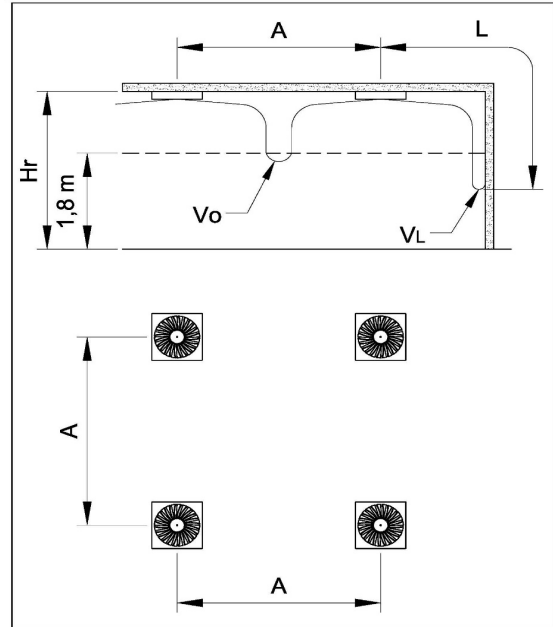
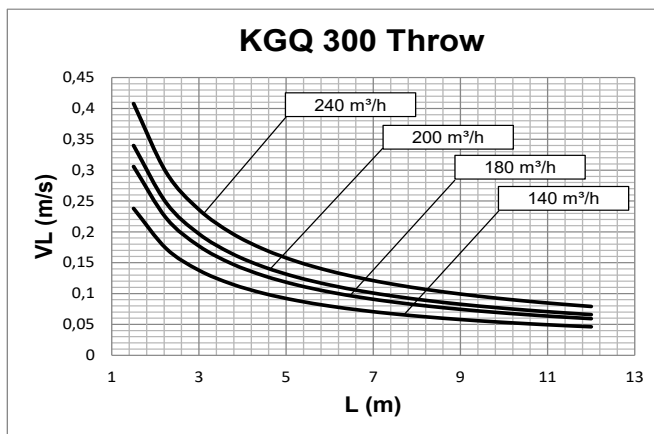
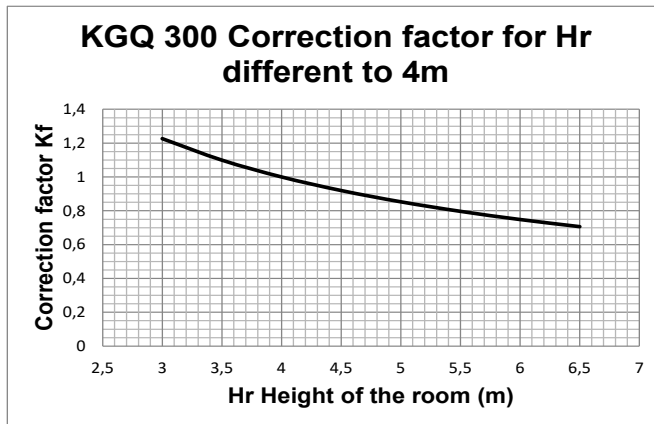
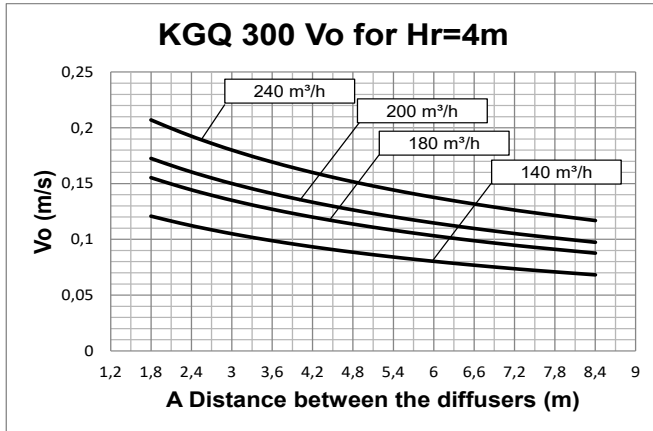

Data obtained operating in isothermal conditions in accordance with the international standard: ISO 5219 1984: *Air distribution and air diffusion - Laboratory. Aerodynamic testing and rating of air terminal devices.*

A (m) distance between the diffusers
 Vo (m/s) speed at the limit of the occupied zone
 L (m) horizontal distance in metres from the centre of the diffuser
 VL (m/s) maximum speed in the air stream

For Hr different from 4m:
 $V_o(h) = V_o \times K_f$

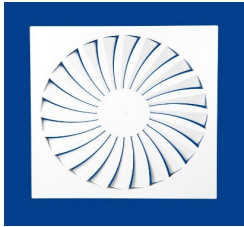

HIGH-INDUCTION DIFFUSERS FOR COUNTERCEILING

PERFORMANCE KGQ-300

KGQ
SERIES

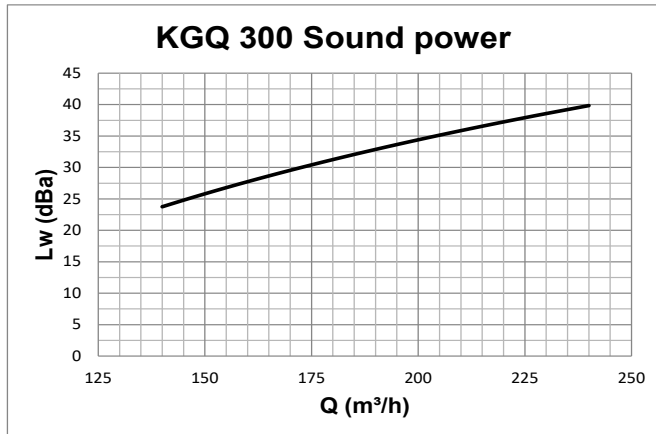

Data measured in reverberation room in accordance with international standards:

ISO 3741 1999: *Acoustic - determination of sound power levels of noise sources using sound pressure - Precision methods for reverberation rooms*

ISO 5135 1997: *Acoustic - determination of sound power levels of noise from air-terminal devices ; air terminal units; dampers and valves by measurement in a reverberation room.*

The data presented does not consider the attenuation given by the area of installation. This attenuation is normally between 6 and 10 dBA and is determined by the room size, the shape of the environment and the interior features.

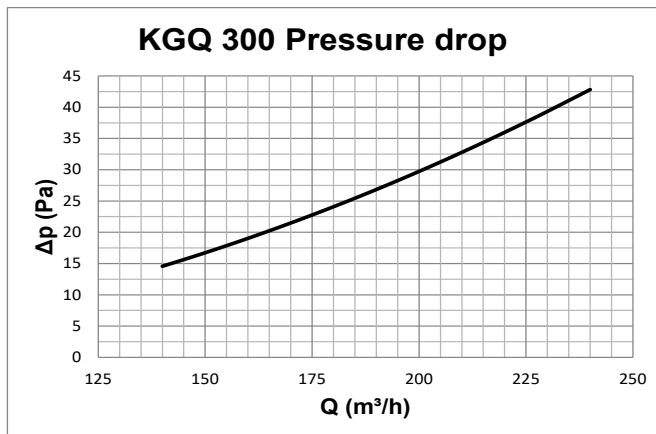

Data obtained operating in accordance with the international standard:

ISO 5219 1984: *Air distribution and air diffusion - Laboratory. Aerodynamic testing and rating of air terminal devices.*

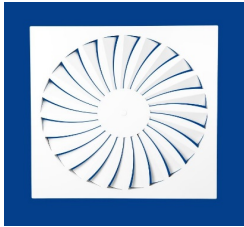

HIGH-INDUCTION DIFFUSERS FOR COUNTERCEILING

PERFORMANCE KGQ-400

KGQ
SERIES

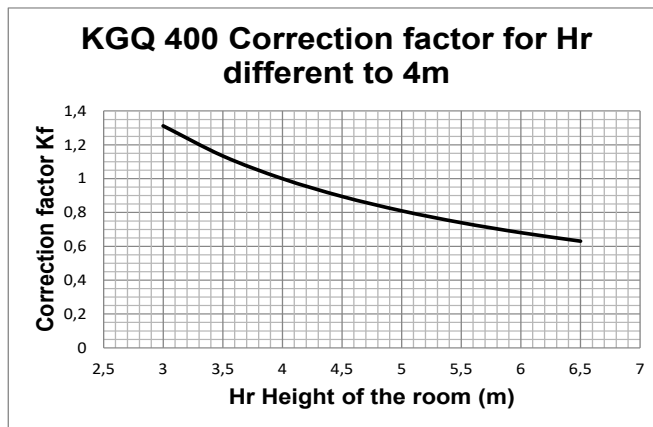
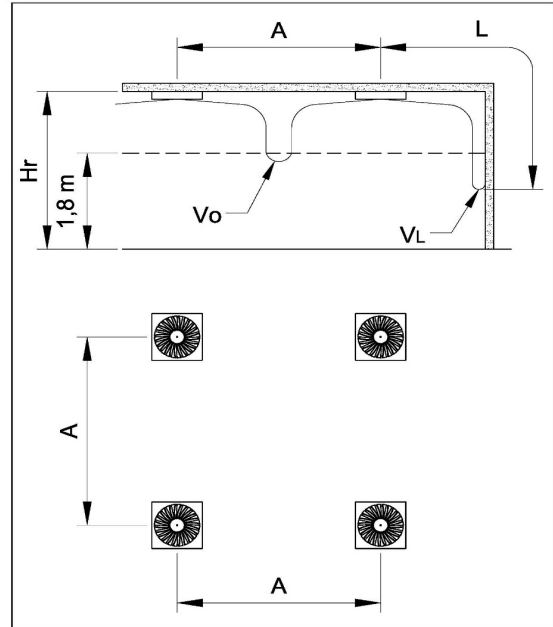
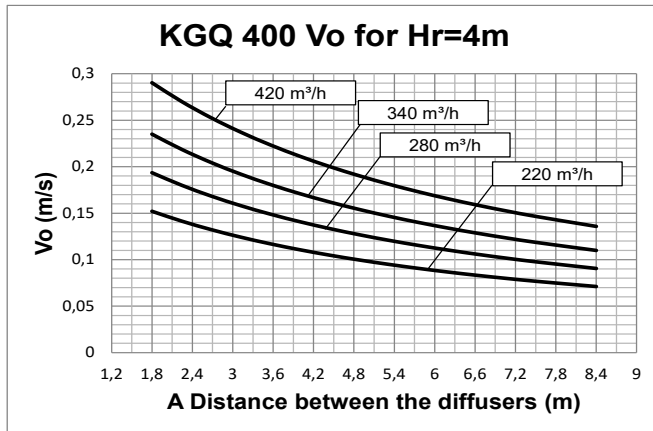

Data obtained operating in isothermal conditions in accordance with the international standard: ISO 5219 1984: *Air distribution and air diffusion - Laboratory. Aerodynamic testing and rating of air terminal devices.*

A (m) distance between the diffusers
 Vo (m/s) speed at the limit of the occupied zone
 L (m) horizontal distance in metres from the centre of the diffuser
 VL (m/s) maximum speed in the air stream

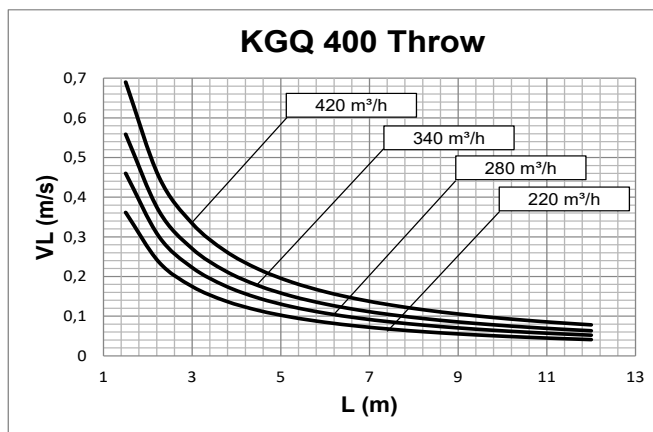

For Hr different from 4m:
 $Vo(h) = Vo \times Kf$

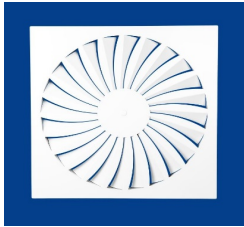

HIGH-INDUCTION DIFFUSERS FOR COUNTERCEILING

KGQ
SERIES

PERFORMANCE KGQ-400

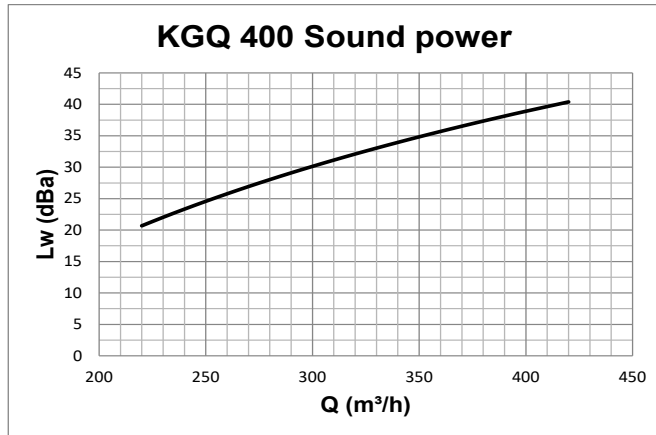

Data measured in reverberation room in accordance with international standards:

ISO 3741 1999: *Acoustic - determination of sound power levels of noise sources using sound pressure - Precision methods for reverberation rooms*

ISO 5135 1997: *Acoustic - determination of sound power levels of noise from air-terminal devices; air terminal units; dampers and valves by measurement in a reverberation room.*

The data presented does not consider the attenuation given by the area of installation. This attenuation is normally between 6 and 10 dBA and is determined by the room size, the shape of the environment and the interior features.

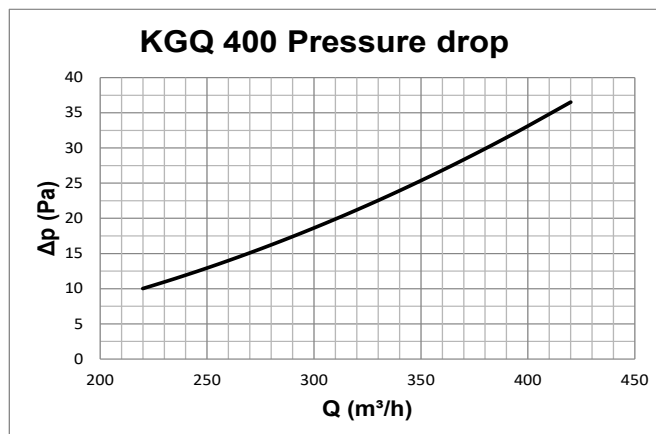

Data obtained operating in accordance with the international standard:

ISO 5219 1984: *Air distribution and air diffusion - Laboratory. Aerodynamic testing and rating of air terminal devices.*

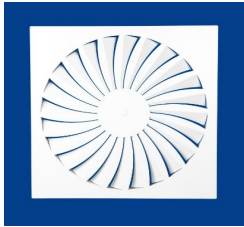

HIGH-INDUCTION DIFFUSERS FOR COUNTERCEILING

PERFORMANCE KGQ-500

KGQ
SERIES

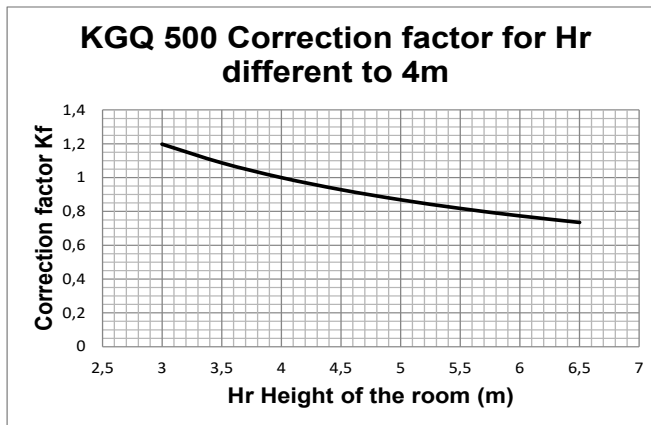
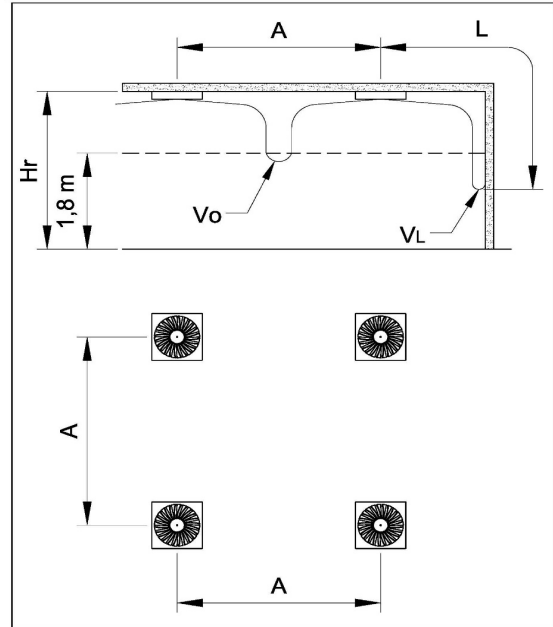
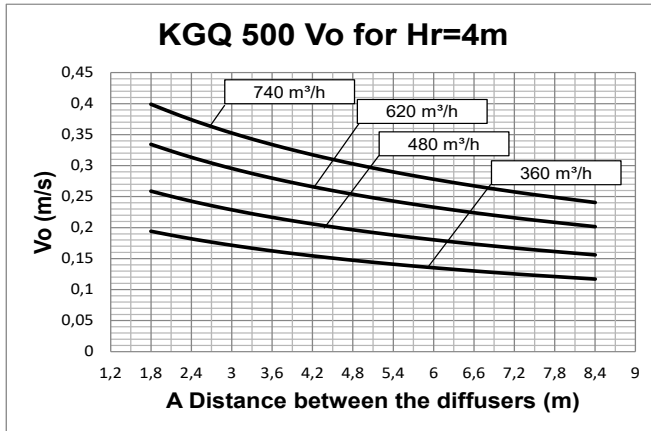

Data obtained operating in isothermal conditions in accordance with the international standard: ISO 5219 1984: *Air distribution and air diffusion - Laboratory. Aerodynamic testing and rating of air terminal devices.*

A (m) distance between the diffusers
 Vo (m/s) speed at the limit of the occupied zone
 L (m) horizontal distance in metres from the centre of the diffuser
 VL (m/s) maximum speed in the air stream

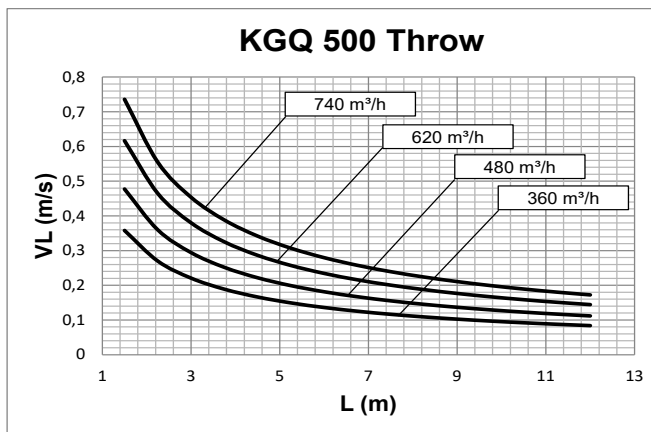

For Hr different from 4m:
 $Vo(h) = Vo \times Kf$

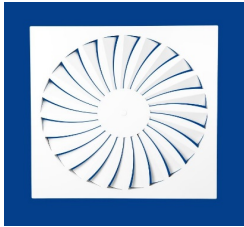

HIGH-INDUCTION DIFFUSERS FOR COUNTERCEILING

PERFORMANCE KGQ-500

KGQ
SERIES

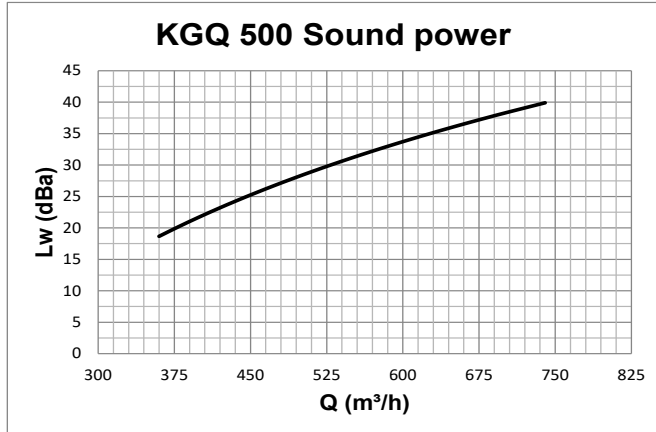

Data measured in reverberation room in accordance with international standards:

ISO 3741 1999: *Acoustic - determination of sound power levels of noise sources using sound pressure - Precision methods for reverberation rooms*

ISO 5135 1997: *Acoustic - determination of sound power levels of noise from air-terminal devices ; air terminal units; dampers and valves by measurement in a reverberation room.*

The data presented does not consider the attenuation given by the area of installation. This attenuation is normally between 6 and 10 dBA and is determined by the room size, the shape of the environment and the interior features.

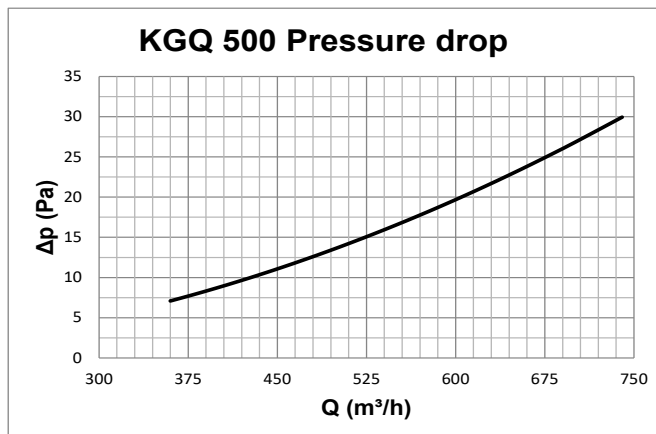

Data obtained operating in accordance with the international standard:

ISO 5219 1984: *Air distribution and air diffusion - Laboratory. Aerodynamic testing and rating of air terminal devices.*

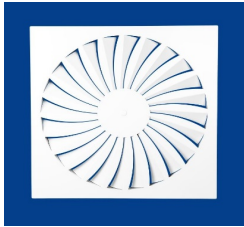

HIGH-INDUCTION DIFFUSERS FOR COUNTERCEILING

PERFORMANCE KGQ-600

KGQ
SERIES

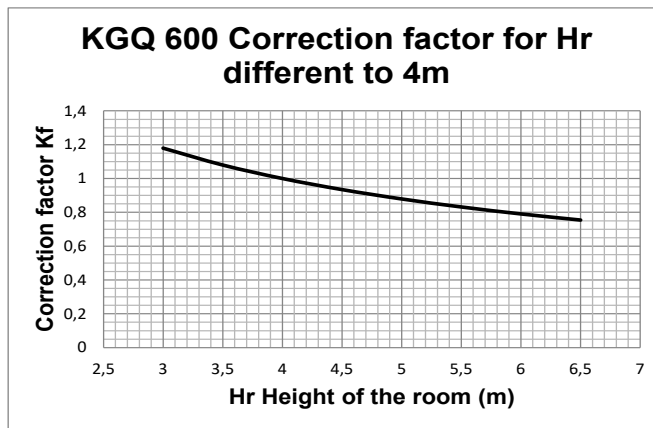
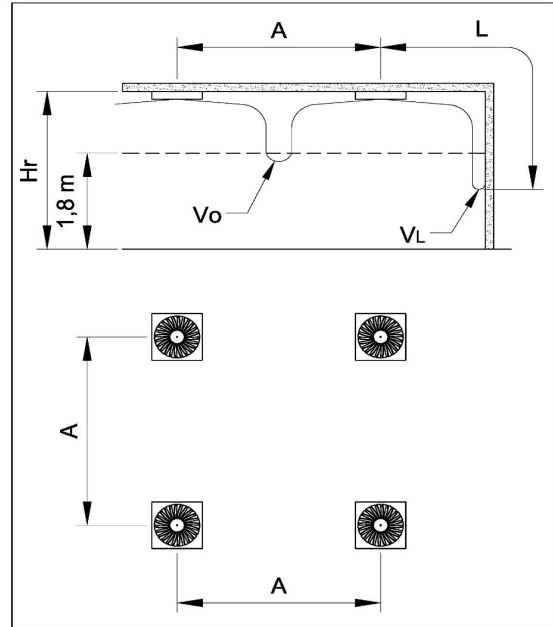
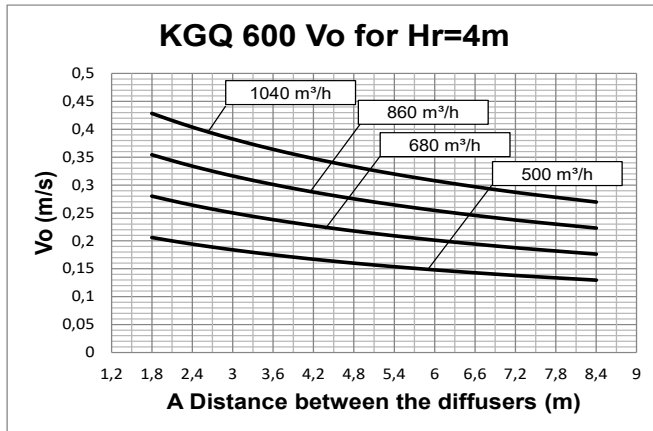

Data obtained operating in isothermal conditions in accordance with the international standard: ISO 5219 1984: *Air distribution and air diffusion - Laboratory. Aerodynamic testing and rating of air terminal devices.*

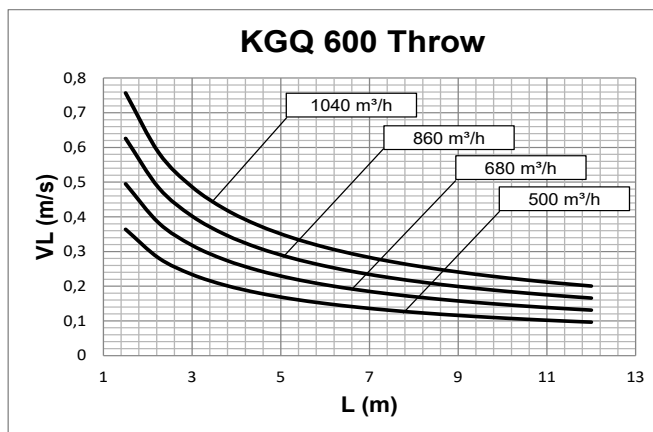

A (m) distance between the diffusers
 Vo (m/s) speed at the limit of the occupied zone
 L (m) horizontal distance in metres from the centre of the diffuser
 VL (m/s) maximum speed in the air stream

For Hr different from 4m:
 $V_o(h) = V_o \times K_f$

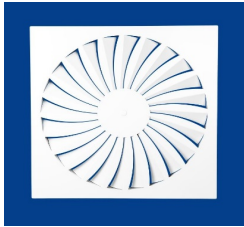

HIGH-INDUCTION DIFFUSERS FOR COUNTERCEILING

PERFORMANCE KGQ-600

KGQ
SERIES

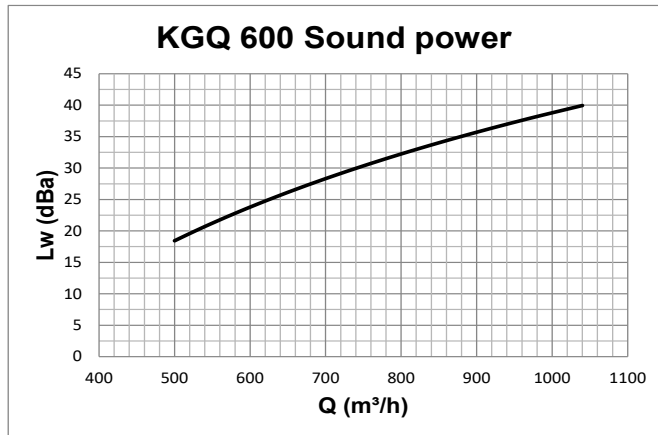

Data measured in reverberation room in accordance with international standards:

ISO 3741 1999: *Acoustic - determination of sound power levels of noise sources using sound pressure - Precision methods for reverberation rooms*

ISO 5135 1997: *Acoustic - determination of sound power levels of noise from air-terminal devices ; air terminal units; dampers and valves by measurement in a reverberation room.*

The data presented does not consider the attenuation given by the area of installation. This attenuation is normally between 6 and 10 dBA and is determined by the room size, the shape of the environment and the interior features.

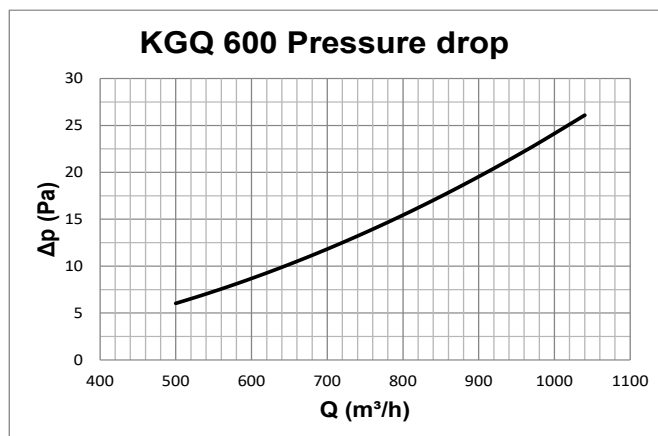

Data obtained operating in accordance with the international standard:

ISO 5219 1984: *Air distribution and air diffusion - Laboratory. Aerodynamic testing and rating of air terminal devices.*

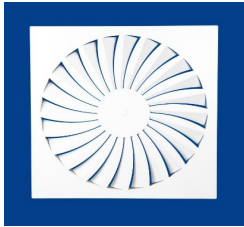

HIGH-INDUCTION DIFFUSERS FOR COUNTERCEILING

PERFORMANCE KGQ-625

KGQ
SERIES

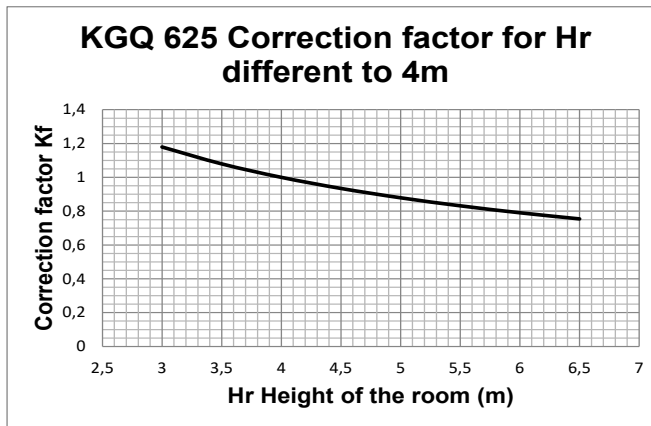
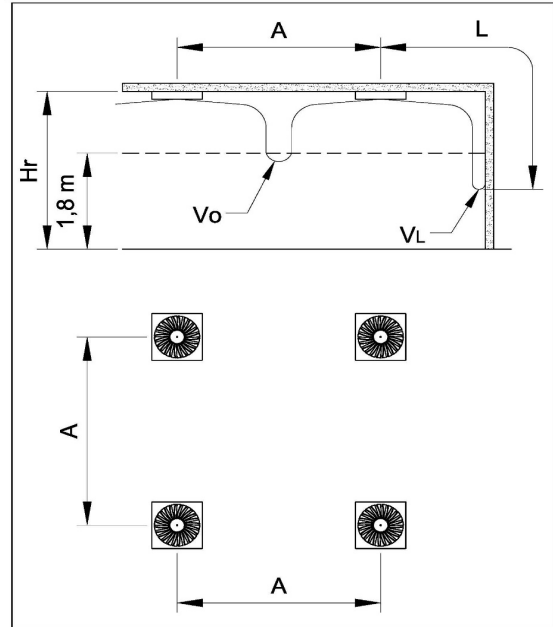
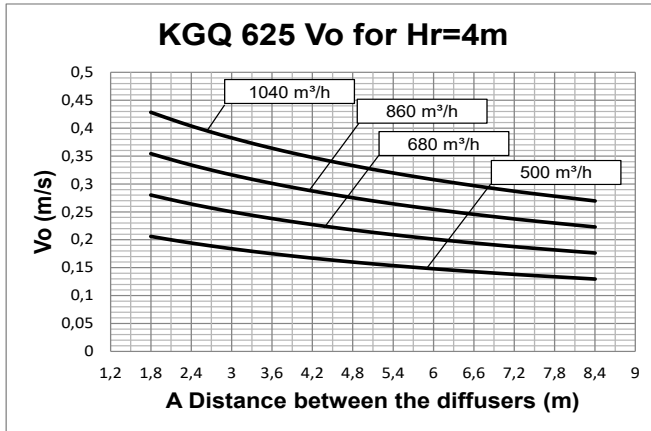

Data obtained operating in isothermal conditions in accordance with the international standard: ISO 5219 1984: *Air distribution and air diffusion - Laboratory. Aerodynamic testing and rating of air terminal devices.*

A (m) distance between the diffusers
 Vo (m/s) speed at the limit of the occupied zone
 L (m) horizontal distance in metres from the centre of the diffuser
 VL (m/s) maximum speed in the air stream

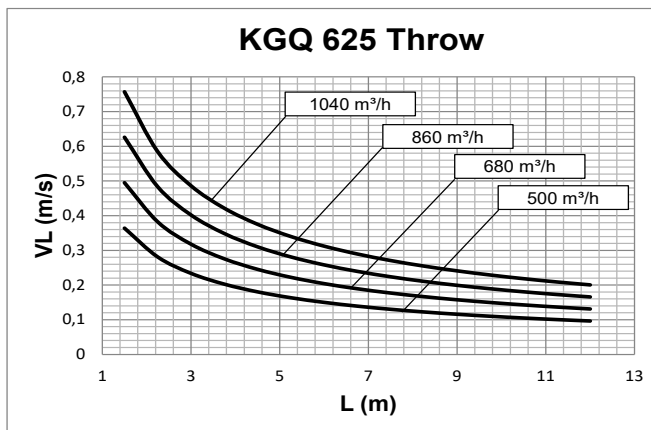

For Hr different from 4m:
 $V_o(h) = V_o \times K_f$

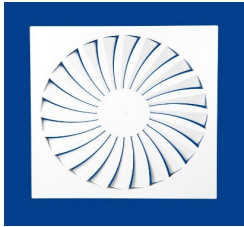

HIGH-INDUCTION DIFFUSERS FOR COUNTERCEILING

PERFORMANCE KGQ-625

KGQ
SERIES

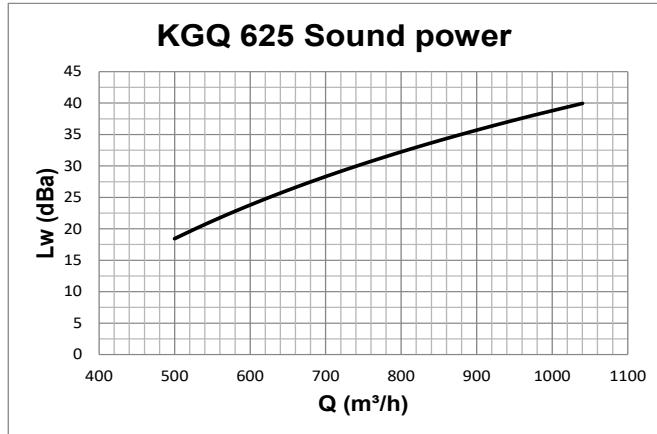

Data measured in reverberation room in accordance with international standards:

ISO 3741 1999: *Acoustic - determination of sound power levels of noise sources using sound pressure - Precision methods for reverberation rooms*

ISO 5135 1997: *Acoustic - determination of sound power levels of noise from air-terminal devices ; air terminal units; dampers and valves by measurement in a reverberation room.*

The data presented does not consider the attenuation given by the area of installation. This attenuation is normally between 6 and 10 dBA and is determined by the room size, the shape of the environment and the interior features.

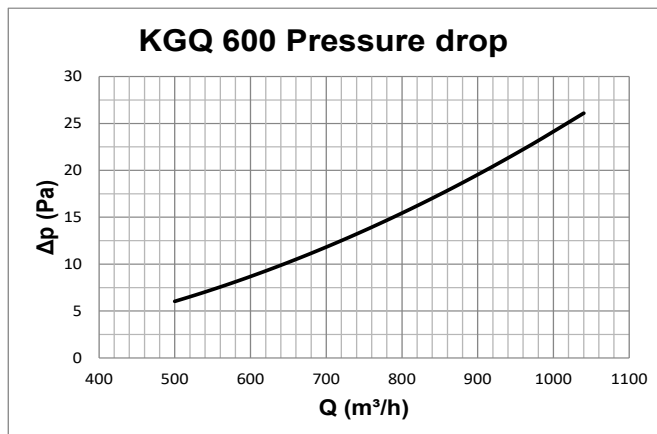

Data obtained operating in accordance with the international standard:

ISO 5219 1984: *Air distribution and air diffusion - Laboratory. Aerodynamic testing and rating of air terminal devices.*

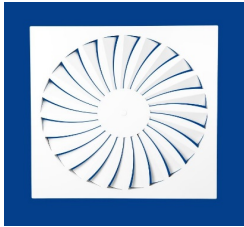

HIGH-INDUCTION DIFFUSERS FOR COUNTERCEILING

KGQ
SERIES

HOW TO ORDER

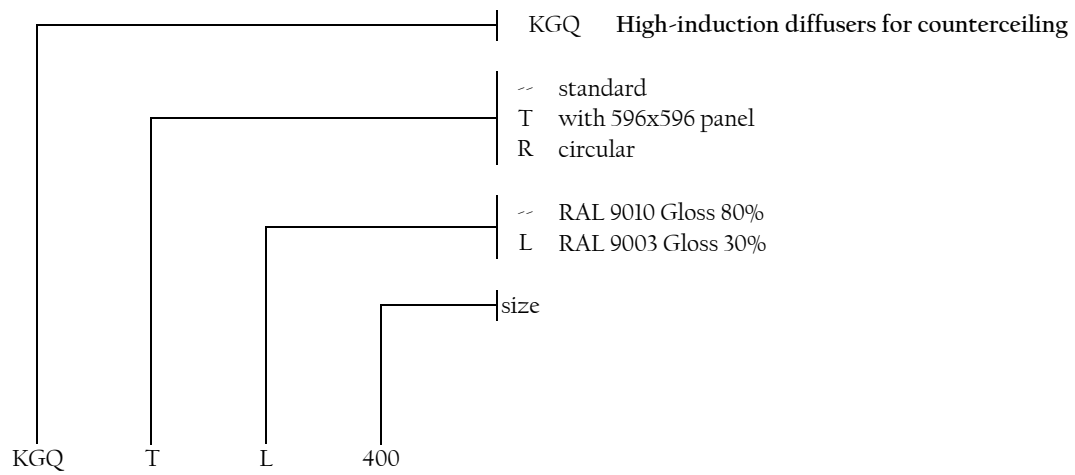

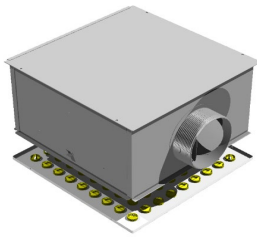

PLENUM FOR DIFFUSERS HIGH INDUCTION

PP80
PP81

PLENUM IN SEEL SHEET

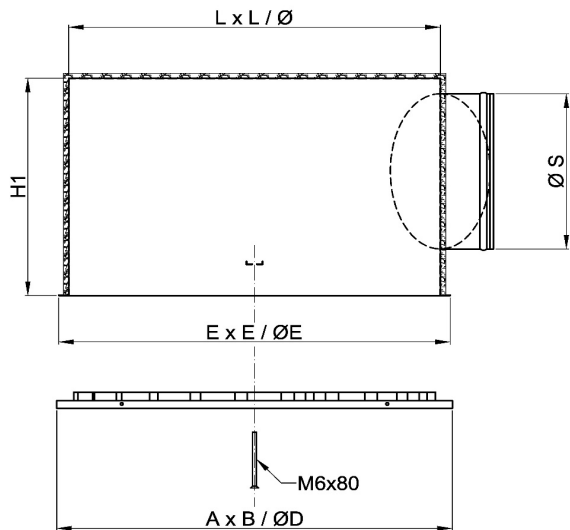

PLENUM PP80

Made of galvanized sheet steel.

Lateral connection.

Mounting bridge for mounting diffuser with central screw.

Complete with hooks for ceiling suspension.

optionals:

polyethylene insulation;

equalizer steel mesh;

control damper into the fitting.

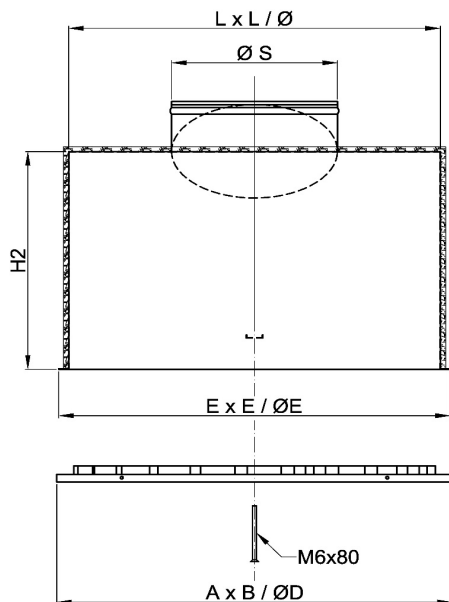

PLENUM PP81

Made of galvanized sheet steel.

Rear connection.

Mounting bridge for mounting diffuser with central screw.

Complete with hooks for ceiling suspension.

optionals:

polyethylene insulation;

equalizer steel mesh;

control damper into the fitting.

Nominal size of the diffuser	AxB ØD	L x L Ø	E x E ØE	H1	H2	N° connec- tions	S	Connection and damper material
300	296	260	290	250	150	1	123	ABS (*)
400	396	360	390	350	200	1	195	ABS (*)
500	496	460	490	350	200	1	195	ABS (*)
600	596	560	590	350	200	1	245	ABS (*)
625	621	585	615	350	200	1	245	ABS (*)
800	796	760	790	400	250	1	296	steel
825	821	785	815	400	250	1	296	steel

(*) Steel on request



PLENUM FOR DIFFUSERS HIGH INDUCTION

PP80
PP81

HOW TO ORDER

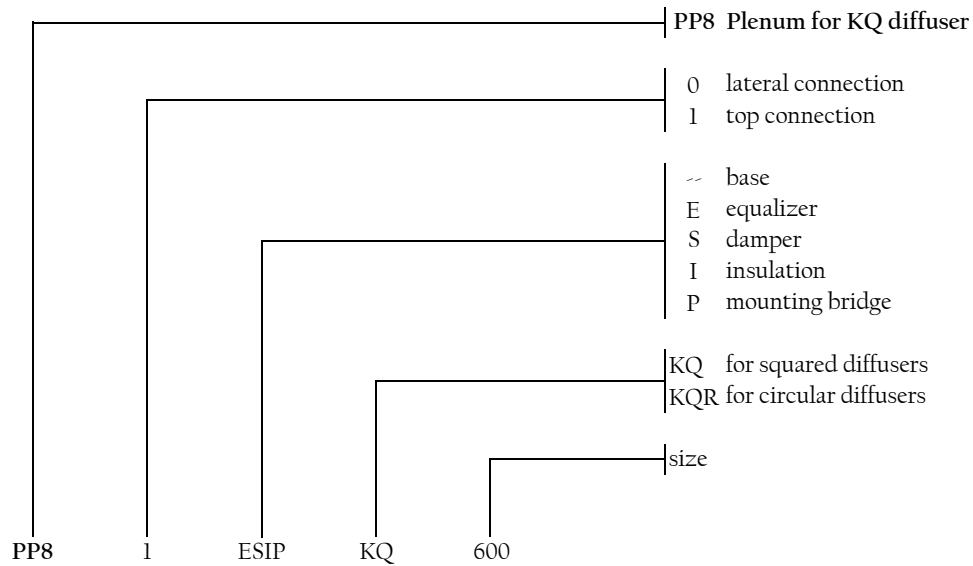

Standard sizes
200
300
400
500
600
625
800
825