



CIRCULAR REGULATION DAMPER DIN 1946 GUARANTEE

CL-SRC
SERIES

OVERVIEW

Overview :

The CL-SRC series of circular regulation dampers are units commonly used for the regulation of air circulation systems.

Technical characteristics :

The CL-SRC dampers are made by:

- circular covering in galvanized steel sheeting with diameters from 125 to 710 mm, corresponding to the standard diameters for circular air flow ducts;
- regulation damper of air flow in galvanised steel with rubber ring to guarantee the maximum linearity in the regulation and level of noise;
- command hinge with a diameter suitable to the diameter of the equipment;
- bronze ringlets for the hinge support;
- The complete shut-off is certified to EN 1751-EN 1886 specifications.

Special assembly requests:

Assembly in stainless steel AISI 304

Assembly in stainless steel AISI 316

Applications:

The CL-SRC series dampers are used to balance the air flow in ventilation and conditioning systems.

Noise emitting tests have been done following ENISO 3741 regulations.

Description summary :

Circular regulation dampers, CL-SRC series, made from galvanized steel (or other material).

Accessories :

- flange drilled and stamped;
- manual command R9 (Ø8 hinge);
- manual command R11 (Ø12 hinge);
- command via electrical motor;
- Pressure operated command with double effect piston.

Main dimensions

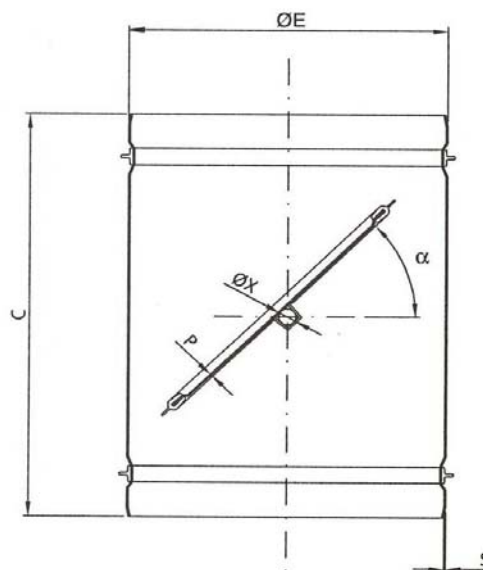

ØE	C	S	ØX	P
mm	mm	mm	mm	mm
125	200	0,8	8	0,8
160	200	0,8	8	0,8
200	200	0,8	8	0,8
250	200	0,8	8	0,8
300	300	1,0	12	1,2
315	300	1,0	12	1,2
355	300	1,0	12	1,2
400	400	1,2	12	1,5
450	400	1,2	12	1,5
500	400	1,2	12	1,5
560	400	1,5	12	2,0
630	400	1,5	12	2,0



CIRCULAR REGULATION DAMPER
DIN 1946 GUARANTEE

CL-SRC
SERIES

PERFORMANCE

TRANSMITTED SOUND									
Ø	α°	V	ΔPt	LwA	Ø	α°	V	ΔPt	LwA
100	20	4	48	37	250	20	4	15	31
		7	102	46			6	22	39
		9	178	54			10	52	50
		14	355	64			15	129	63
	45	4	178	48		45	3,5	48	38
		5,5	295	54			5	120	50
		7,5	57	563			8	278	61
		11	1180	73			12	618	72
	60	2	259	42		60	1,5	65	36
		2,5	460	52			3	222	50
		3,5	720	58			4,5	498	61
		4,5	1020	62			6,5	925	71
200	20	4	20	33	400	20	4	6	33
		6	37	41			6	18	40
		10	92	52			10	35	53
		15	240	67			12	51	58
	45	3	89	42		45	3,5	45	38
		5	255	56			5	95	49
		8	555	67			8	235	61
		12	1152	78			12	562	73
	60	1,5	125	41		60	1,5	59	38
		2,5	305	52			3	201	54
		3,5	620	62			4,5	462	63
		4,5	1015	69			6,5	912	72

IRRADIATED SOUND							
Ø	α°	V	LwA	Ø	α°	V	LwA
200	20	15	51	400	20	12	49
	45	8	53		45	8	49
	60	5	56		60	5	52
250	20	15	54				
	45	8	51				
	60	5	55				

- α= opening angle (0°=completely opened)
- V= velocity referring to section ØE (m/s)
- ΔPt Total pressure loss (Pa)
- LwA= Sound power level (dB(A))



CIRCULAR REGULATION DAMPER
DIN 1946 GUARANTEE

CL-SRC
SERIES

CODES

CODES FOR DAMPERS PREPARED FOR MANUAL CONTROL	
CODE	DIAMETER mm
CL-SRCTG125M	125
CL-SRCTG160M	160
CL-SRCTG200M	200
CL-SRCTG250M	250
CL-SRCTG315M	315
CL-SRCTG355M	355
CL-SRCTG400M	400
CL-SRCTG450M	450
CL-SRCTG500M	500
CL-SRCTG560M	560
CL-SRCTG630M	630

Manual comand lever for Ø8 hinge (diameters from 125 to 250 included):

CL-SRCR9

Manual comand lever for Ø12 hinge (diameters from 315 to 630 included):

CL-SRCR11